

GBJ166

# Youth Market Lamb Project Guide

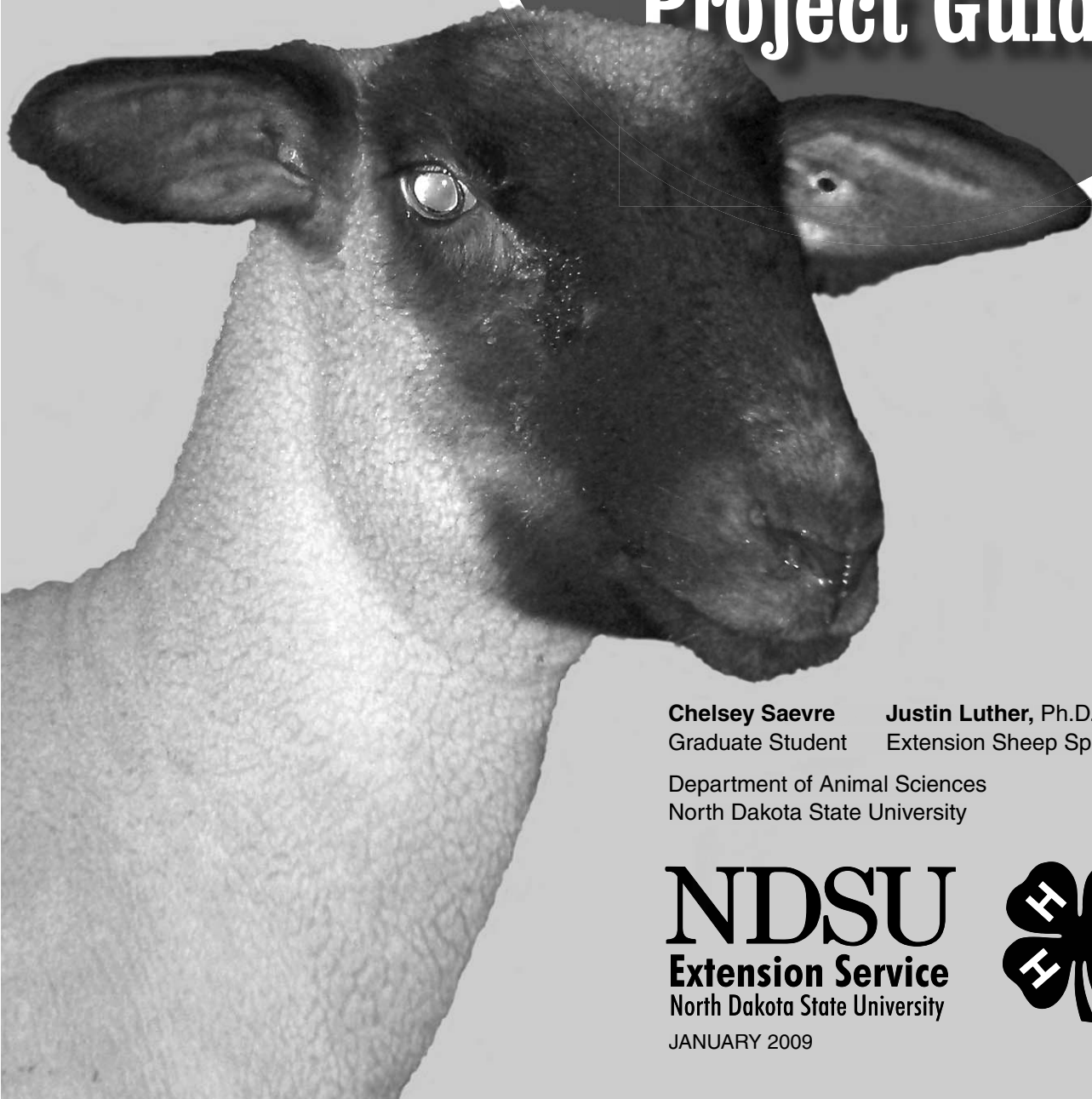

**Chelsey Saevre**  
Graduate Student

**Justin Luther, Ph.D.**  
Extension Sheep Specialist

Department of Animal Sciences  
North Dakota State University

**NDSU**  
**Extension Service**  
North Dakota State University



JANUARY 2009



# Introduction

---

**Y**ou have made the choice to participate in the youth market lamb project with nearly 1,000 other youth from throughout North Dakota. Although the project is designed to be a fun learning experience, it will require a lot of time and effort from your entire family. Parents and project mentors, in particular, must be committed to supporting your project. During the next few months, you will have the opportunity to develop a stronger work ethic, self-discipline, patience, commitment, professionalism and a sense of achievement. Even though your project may be completed by the end of the summer, the skills and additional experiences gained will stay with you for a lifetime.

Throughout the spring and summer, a successful market lamb project has many components. You will be introduced to most of the basic concepts that are necessary in every successful livestock operation. These include goal setting, selection, recordkeeping, nutritional management, proper animal health care, animal husbandry and handling techniques, and livestock marketing. If your involvement in the youth market lamb project progresses from year to year, you even may have the opportunity to advise other members of your 4-H club or FFA chapter as they get started in the project. This will give you the opportunity to learn leadership skills and even serve as a role model to younger members.

This guide has been developed to help you get started and will serve as a resource throughout your project. Becoming familiar with this guide before your project starts will help you remain conscious and aware of the dynamics of the youth market lamb program. In addition, this guide may help you realize all of the work and responsibility that is involved before making a commitment to the project.

## Contents

Evolution of the Club Lamb Industry .....	3
Facilities.....	4
Equipment .....	6
Selection.....	9
Health .....	15
Nutrition and Exercise .....	17
Fitting.....	20
Training Your Lamb to Show.....	21
Showmanship .....	24
Common Showmanship Questions .....	26
Establishing Project Goals.....	27



# Evolution of the Youth Market Lamb Project

---

**Y**ou can find more than 1,000 breeds of sheep in the world. Each will have certain traits or characteristics that make it better suited for a particular environment or consumer demand when compared with others. Even within a particular breed, sheep producers will disagree upon which traits should receive more emphasis or selection pressure than others. Approximately 30 years ago, breeders of Hampshire and Suffolk sheep began to disagree greatly upon which traits should receive more emphasis than others. Some breeders felt that more selection pressure should be placed on traits such as muscling, leanness and levelness of design, whereas others felt that selection pressure should be placed growth, mature frame size and breed character. While both of these breeder groups continued to emphasize structural correctness, they obviously took their respective breeds in separate directions to meet the demands of their customers. Today, within the Suffolk, Hampshire, Dorset and even Rambouillet breeds, we see distinct differences among sheep that have been developed for youth market lamb projects (Figure 1) versus those that have not been selected for this purpose (Figure 2). Therefore, for an individual to be competitive within the market lamb project, he or she generally will need to purchase his or her lamb(s) from a designated club lamb breeder.



**Figure 1. Suffolk market lamb bred for youth market lamb projects and exhibited at the 2007 Iowa State Fair.**



**Figure 2. Suffolk ram lamb exhibited at the 2007 Iowa State Fair.**

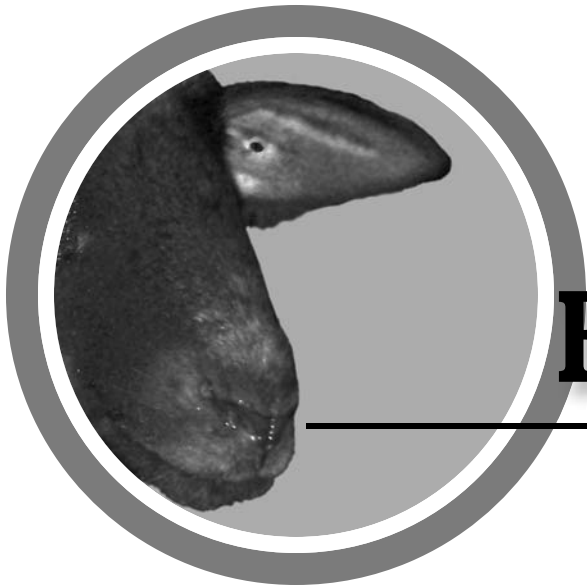

# Facilities

**F**acilities for your new project can be as complex or as simple as you feel you need them to be to achieve your goals. A good housing area for your show lambs should be well-ventilated, dry and clean. The area should be elevated, well-drained and face toward the east or south for protection from wind, rain and other adverse weather conditions. Electricity and water availability is convenient but not completely necessary if these amenities are in relative proximity.

Pen size recommendations will vary with the number of lambs, their age and size. The average show lamb requires a minimum of 24 square feet of indoor pen space to achieve acceptable performance. A larger outdoor dry lot adjacent

to the indoor pen space also is necessary. This serves two functions; it allows lambs access to fresh air and promotes exercise throughout the day. However, you also will need to provide additional exercise for your lamb, and this will be discussed later in the guide.

## Estimated Dry Lot Space Requirements

Number of Lambs	Recommended Dry Lot Size
1	100 ft <sup>2</sup>
2	200 ft <sup>2</sup>
3	250 to 300 ft <sup>2</sup>
4-5	350 to 400 ft <sup>2</sup>
6+	500+ ft <sup>2</sup>

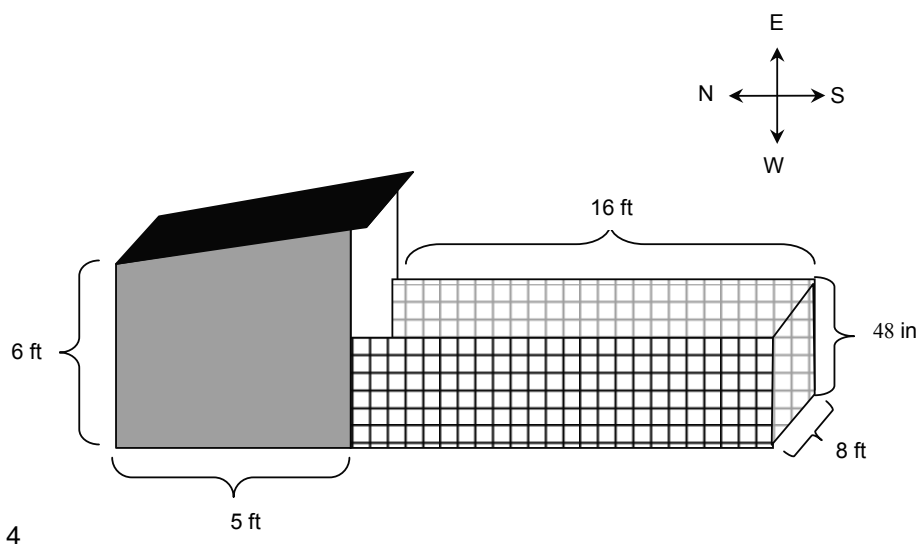

**Figure 3. Example of an outdoor shelter for market lambs. Increasing total square footage will allow adequate space for multiple market lambs.**

Fences surrounding the outdoor dry lot should be at least 48 inches high, inhibiting sheep from escaping and preventing the entrance of predators, such as coyotes or stray dogs. The list of materials for fence making is endless; however, woven wire tends to work better than other materials. Woven wire is made from smooth wire that is crosshatched in a horizontal and vertical pattern. Animals can see the crosshatches easily, making a good physical barrier. The smooth wire reduces the incidence of injuries to your sheep. Cost and difficult installation can be some of the disadvantages of woven wire.

Cattle panels also can be used as dry lot fences for show lambs. These flexible and strong crosshatched panels also can be used for gathering sheep or for loading purposes. Cost and installation are disadvantages of cattle panels.

Barbed wire is used extensively for large species, such as horses, cattle, etc. However, it should not be used for market lambs, particularly for a small operation. Strands of barbed wire allow easy access for predators, sheep can escape easily and the barbs can cause serious damage if skin comes in direct contact with it.

Although many types of floor surfaces for your indoor facility are acceptable (dirt, concrete, etc.), the type of bedding you choose is critical to your lambs' comfort and performance. Lambs raised on clean, comfortable and fresh bedding will achieve higher average daily gains. Bedding should be cleaned and replaced on a weekly basis and more frequently if necessary, depending on the degree of moisture and ammonia buildup in the pen. Continuous exposure to wet, stagnant bedding may cause health concerns for your lamb. Acceptable types of bedding include wood shavings, straw or other crop residues, depending on cost and availability.

The most common and recommended type of bedding to use for your show lambs is wood shavings. Wood shavings are available in many styles; however, cedar shavings tend to be the healthiest for lambs due to a larger particle size and low dust level. When purchasing shavings, noticing the particle size and cleanliness of the shavings is important. Small and dirty particles will have higher levels of dust. Dusty bedding can cause irritation in the lambs' upper respiratory tract, resulting in snotty noses, wheezing and coughing. Excessive coughing ultimately can lead to rectal prolapsing and/or other health issues that are detrimental to the performance of your lamb.

Crop residues (straw, corn stalks, soybean stems, hulls, etc.) are commonly used throughout the winter and early spring months to keep lambs warm and pen floors well-insulated. During the heat of the summer, crop residues are rarely used due to their large particle size and high dust levels, and lamb consumption of these products can lead to decreased performance. Lambs often will consume crop residues, giving them a "full" or enlarged belly appearance. Since this takes away from the overall attractiveness of the lamb, bedding consumption should be avoided.

Whichever bedding you choose, make sure the lamb is comfortable, clean and dry. In addition, make sure that bedding consumption is not decreasing your show lambs' performance.



# Equipment

---

**E**quipment used for raising show lambs can be very minimal or quite extensive, depending on the goals of your project. Listed below are a few commonly found items in a show lamb barn. Most of these items can be purchased at your local farm store or through a livestock supplies dealer. When considering large pieces of equipment (for example, clippers, blowers, trimming stands, etc.), cost can be prohibitive. If several members in your youth organization are interested in sheep, consider asking your club or chapter to purchase some equipment to share among the members.

## Water Trough

Water is a critical nutrient that is essential for achieving optimal growth and development. Clean, fresh water should be available to the lamb(s) at all times. The water trough should be in a dry, cool area inside the barn and out of the sunlight. Troughs should be rinsed and scrubbed weekly to avoid the buildup of harmful bacteria. Avoid using strong detergents or soaps because the fragrance in some products may reduce water consumption. A lamb will consume 1 to 2.5 gallons of water per day, depending on size. This

will fluctuate further with temperature, intake, feed additives, exercise and overall lamb health. Water never should be fully restricted; however, smaller amounts can be rationed just prior to show day to prevent a “full” or enlarged-belly appearance. This will allow your lamb to have a trimmer appearance.

## Feeders

Proper management of feeders is important for obtaining maximum feed intake and performance. Self feeding units and individual hand feeders both work well in the early stages of growth. However, a hand feeding program is more desirable during the finishing period because it allows intake to be monitored closely, and proper adjustments in intake can be made according to the lamb’s degree of finish. Lambs fed with a self feeder throughout the project will finish out much sooner than lambs fed with a closely monitored hand feeding system.

Self feeders should be approximately 8 inches off the ground to avoid contamination with bedding, feces and urine. Trays should be managed daily to keep the lamb from sorting different feed ingredients and to prevent mold and bacteria buildup. If a lamb is given free access to a complete corn/oat ration, it often will pick out only the corn and leave the remaining mixture behind.

## Other Sheep Equipment

Making sure the lamb receives a balanced portion of all ingredients in the ration while eating is important. Stirring the different grains and other processed feed ingredients within the trays will help solve this problem. Excess dust and fine particles from the ration also can accumulate in the trays. This should be removed on a weekly basis to avoid buildup. If this problem persists or becomes unmanageable, changing rations may be the best option.

When starting a hand feeding program, try to avoid feeding close to the ground. Hang the feeders at lamb shoulder height and increase feeder heights as needed. Feeding at shoulder height or even higher will train the lamb to keep its head up and also will avoid any fecal or urine contamination. These feeders should be managed daily and scrubbed on a weekly basis. Once again, avoid the use of strong detergents that may reduce lamb intake.

If accurate feed monitoring is an issue, consider building individual feeding stalls. A feeding stall will serve as an area for the lamb to consume the feed without the competition of its pen mates. This management tool is used widely as a way to measure the feed intake of each lamb accurately.



**Figure 4. Lamb Blanket.** Source: Sullivan Show Supply, IA

**Halter** – A halter is needed to lead and maintain control of the lamb; it also can be used during exercise.

**Hose and hose nozzle** – These are used during washing and may be needed to supply your lamb(s) with clean, fresh water.

**Fan** – Throughout the heat of the summer months, a fan should be used to maintain air movement to keep your lambs cool.

**Lamb blanket** – A lamb blanket is used to help keep lambs clean after shearing and before the show. The blanket in Figure 4 consists of a tightly woven canvas available in small (60 to 90 pounds), medium (90 to 110 pounds), large (110 to 140 pounds) and extra-large (140 to 180 pounds) sizes. A blanket with a mesh rear should be used for ewe lambs to avoid urine stains (Figure 4).

**Lamb tube** – A lamb tube is a tightly fitted stretch blanket that keeps lambs clean and tight hided until show time. Tubes come in spandex or cotton materials of various colors. Tubes are available in several sizes: small (50 to 80 pounds), medium (80 to 110 pounds), large



**Figure 5. Lamb Tube.** Source: Sullivan Show Supply, IA.

(110 to 140 pounds) and extra-large (140 to 165 pounds). Lamb tubes and canvas blankets also can be worn to protect tightly shorn lambs from adverse weather conditions (Figure 5).

**Shovel** – When cleaning lamb pen(s), a shovel can be used to remove bedding or manure from the area. Shovels also should be taken to shows to clean pens afterward.

**Stiff brush** – When cleaning troughs and feeders, a stiff brush should be used to remove buildup of residual feed adequately.

**Hoof trimmers** – Hoof trimmers are needed to maintain proper hoof care throughout your project. Depending on growth, hooves should be trimmed once a month. Trim hooves a week before show day to allow adequate time for healing if accidentally trimmed too closely.

**Bath towels and rags** – These can be used to dry lambs after washing and wipe clean the ears and nose of your lamb(s).

**Blow dryer** – A hot blow dryer will dry the wool quickly between washing and shearing.

**Soap** – Any livestock or dish soap will suffice for bathing lambs.

**Show box** – A box or tote should be designated the show box. This box should hold all or most of the equipment taken to the show.

**Drench gun** – This is used for drenching medication or rehydrating lambs that will not drink. A drench gun also can be used to obtain an appropriate amount of stomach fill on show day if the appetite of your lamb(s) has declined.

**Livestock scale** – A livestock scale is useful to monitor your lamb's weight gain. Lambs should be weighed on a weekly basis. Since scales can be expensive, cooperative ownership may be more feasible.

**Wool card or slicker brush** – This device is used for the wool left on below the knees and hocks of the lamb after shearing. The wool should be carded or pulled in an outward direction and then trimmed with hand shears.

**Hand shank shears** – These shears are used to trim excess wool on the legs to obtain a smooth, heavy-boned appearance.

**Trimming stand** – The trimming stand is useful to restrain lambs while shearing and preparing for show.

**Fly spray** – Fly spray should be used prior, during and after the show to prevent fly strike.

**Clippers with appropriate blade sizes** – Clippers fitted with a 20-tooth comb and four-point cutter or a 23-tooth comb and nine-point cutter can be used to remove a majority of the wool. Most market lamb exhibitors will follow with a set of fine or surgical hair blades to ensure a smooth, tight cut without the appearance of clipper lines.

**Syringes and needles** – Syringes and needles should be available for injection of medications. If giving an intramuscular (IM.) injection, use a 20- or 18-gauge, 1-inch needle. For subcutaneous (SQ) injections, you can use a 20- or 18-gauge, 1½-inch needle. Always use new, sterile needles to reduce chances of infection or injury at the injection site.



# Selection

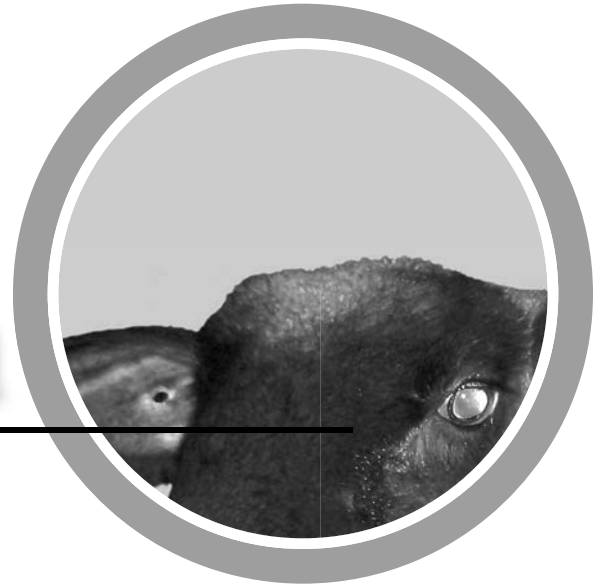

**P**roper selection techniques are critical when attempting to purchase your lamb. The type of lamb(s) you choose will directly influence the management strategies you implement during the summer months. Always remember that a winning lamb is a combination of proper selection, management, nutrition and showmanship.

Selection of young lambs requires patience, practice and well-thought-out project goals. Take time when analyzing a set of lambs and never hesitate to ask for assistance. Project leaders, FFA advisers, breeders and more experienced youth usually are pleased to help in the selection process.

Show lambs can be purchased directly off the farm or from a variety of show lamb sales offered throughout the spring. North Dakota usually has a show lamb sale every weekend in the late spring. Establishing a positive relationship with the breeder(s) of your purchased lamb(s) is encouraged because the breeder can help answer any questions that may arise in the months ahead.

You should take many factors into consideration when selecting your show lamb(s). These factors include, but are not limited to, muscling, structural correctness, balance and eye appeal, and breed.

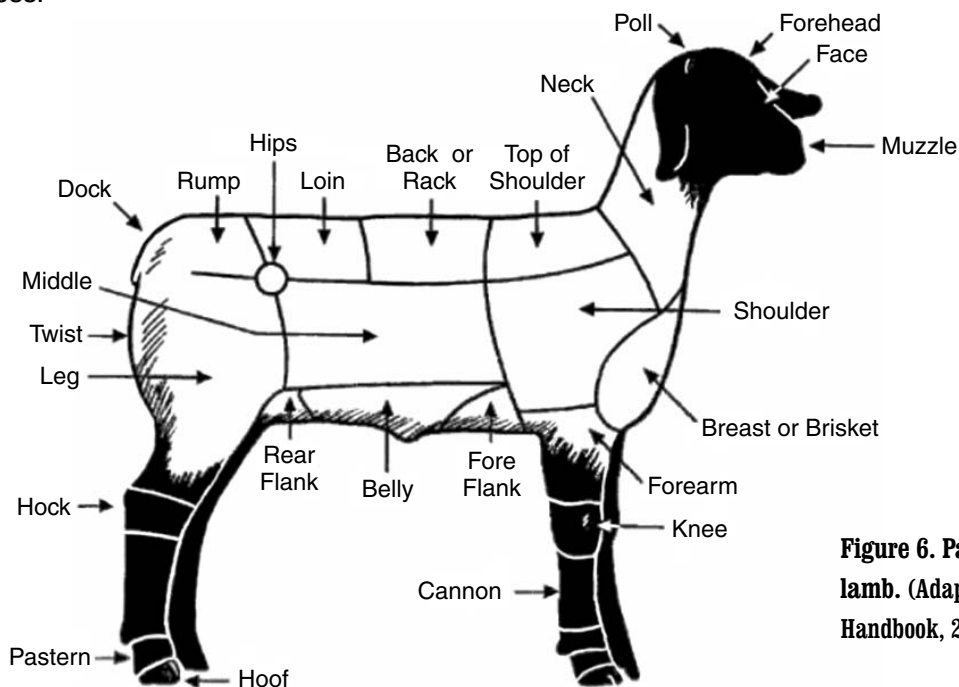

**Figure 6. Parts of the market lamb. (Adapted from Sheep Resource Handbook, 2000)**

## Frame Size and Weight

Exhibitors should remain conscious of the desired weight at which their lamb should be exhibited. To find this optimum weight, place emphasis on frame size and maturity.

Frame size refers to the growth potential of the lamb. Typically, large framed animals will be taller at the top of the shoulder, longer necked, longer bodied and longer in their cannon bone. These lambs should finish or have an appropriate amount of fat deposited at 140 to 155 pounds. Small framed animals are shorter in their overall stature. Typically, they are shorter necked, shorter bodied and shorter through their canon bone than moderate to large framed animals. These lambs should finish at 110 to 125 pounds. Moderate to large framed lambs currently do well in the show ring due to their higher growth potential and later maturity pattern.

Maturity is directly correlated with frame size. Maturity can be defined as the time at which growth of lean tissue declines and fat deposition increases. Usually, larger framed, growthier lambs will be later maturing, reaching heavier market weights before fat deposition begins. These lambs are easier to feed because excessive fat deposition is not a problem that arises early in the project. Small framed, shorter statured lambs will be earlier maturing. Early maturing animals require less days on feed before depositing fat. These lambs are generally selected against due to their lighter finishing weight and high exercise requirements. These lambs often need to maintain a constant weight and degree of finish during the latter weeks or month(s) before the show. For most exhibitors, this is a difficult task. Without careful attention to the degree of finish, small framed lambs can get excessively fat and potentially be penalized in class because they possess less consumable product (a lower muscle-to-fat ratio).

## Muscle

Lambs exhibiting acceptable to superior muscling early in life usually will possess these characteristics as they mature and stay healthy. Some parts of the lamb that should be analyzed for muscling are shown in Figure 7. When handling a lamb, select one that is wide and firm over the center portion of the rack, loin and hip. When viewing the lamb from behind, it should carry muscle volume and dimension down through the center portion of the leg. Also, choose a lamb that stands and strides wide because this is a good indication of future muscle development. When the lamb is finished and taken to slaughter, the remaining carcass will be divided into a fore-saddle and hind-saddle, which are split from one another at the 12th and 13th ribs. Retail cuts coming from the hind-saddle (loin and leg) are more valuable than cuts

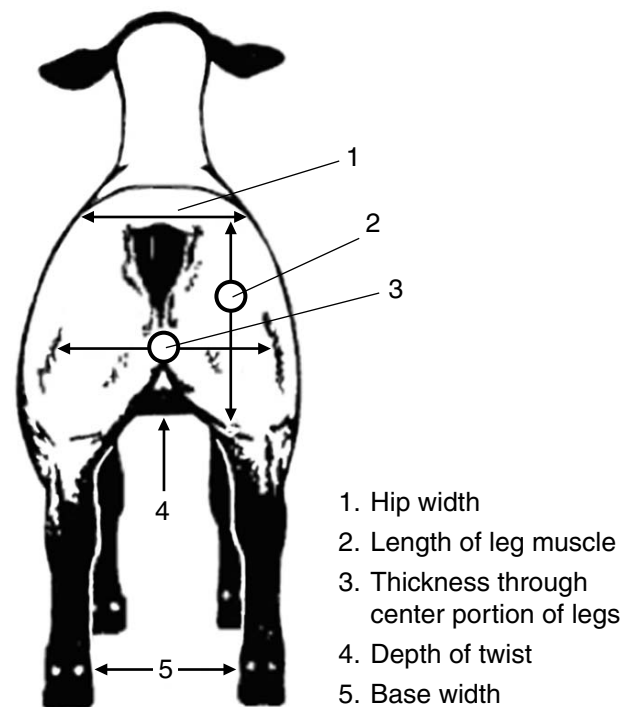

**Figure 7. Parts of the lamb that should be analyzed for muscling. (Adapted from Sheep Resource Handbook, 2000)**

coming from the fore-saddle of the carcass (shoulder and neck). For this reason, selection pressure most often is placed on muscling characteristics in the hind-saddle. Also keep in mind that bigger, older lambs generally will have more muscle development. However, older lambs will not always fit into the time frame of your project. Only lambs that are within the desired age and weight bracket for your project should be selected.

### Structural Correctness

The term structural correctness can be defined as the lamb's ability to maintain a proper skeletal design as it stands and moves about the pen. When analyzing structural correctness, you should select a lamb that exhibits a long and level spine leading into a long, square hip. On the move, the lamb should maintain this levelness with no signs of weakness across the top. The lamb should show adequate bone circumference and hoof size relative to overall frame size and stand on a strong set of pasterns. Hoof placement during the stride should be sound and square, with no visible weaknesses. Avoid lambs that are open shouldered, weak topped and steep hipped. Figure 8 provides common structural problems that can occur with a lamb's feet and legs. Lambs having these structural problems should be avoided.

#### FRONT VIEW

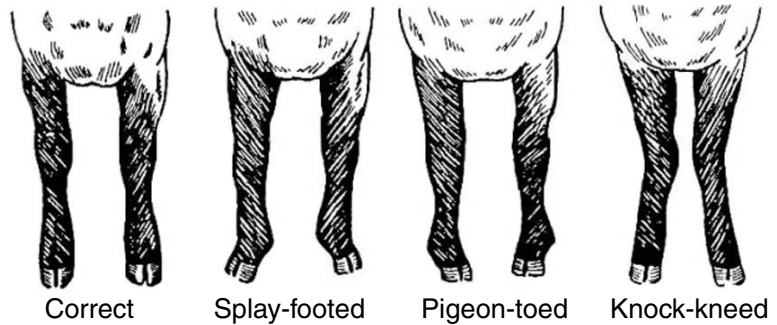

#### REAR VIEW

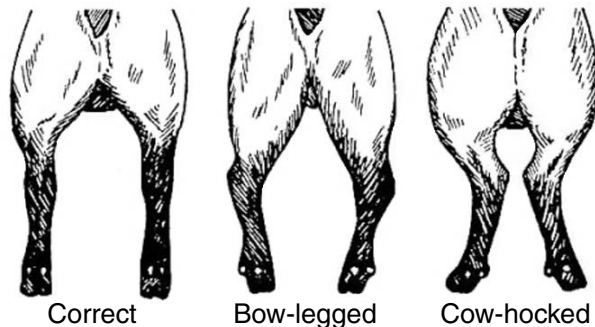

#### SIDE VIEW FRONT LEGS

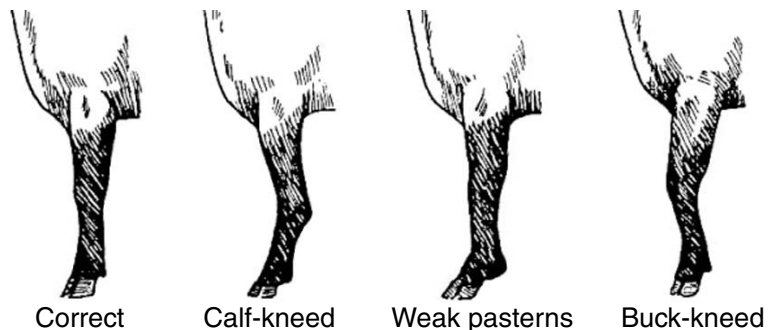

#### SIDE VIEW REAR LEGS

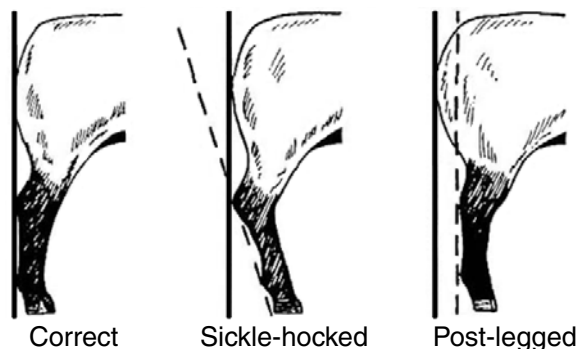

**Figure 8. Common structural problems that can occur with a lamb's feet and legs.**  
(Adapted from Sheep Resource Handbook, 2000)

## Balance

Balance refers to the overall completeness of the lamb. A well balanced lamb is the proper blend of muscle volume, structural correctness and eye appeal. Although balance has no value after slaughter, well balanced lambs generally are more competitive in the show ring. On the profile, the lamb should stand tall at the top of the shoulders with a level top, trim middle and square hip (as shown in Figure 9). In addition, the lamb should possess adequate substance of bone. When analyzing a lamb from the top, it should get wider as you view it from the shoulders to the hip. The shoulders should be tightly set, leading into a firm, wide rack that progressively gets wider as you move your hand back to the hind-saddle.

## Breed

Many breeds of sheep are exhibited as market lambs; however, most black faced breeds (Hampshire or Suffolk) tend to outperform white faced breeds (Dorset, Rambouillet or Southdown) when shown together. Every market lamb show is different. In some cases, all lambs are shown by weight, regardless of breed, while other shows may sort breed and weight classes. Check with your local, state or national show guidelines for class rules and regulations.

Most market shows will classify by breed based on the All-American Market Lamb Show Guidelines. Disqualifications and discriminations are listed below for each breed. This system largely uses the “three strikes you’re out” method for disqualifications; however, some single characteristics also may result in an absolute disqualification (Table 1).

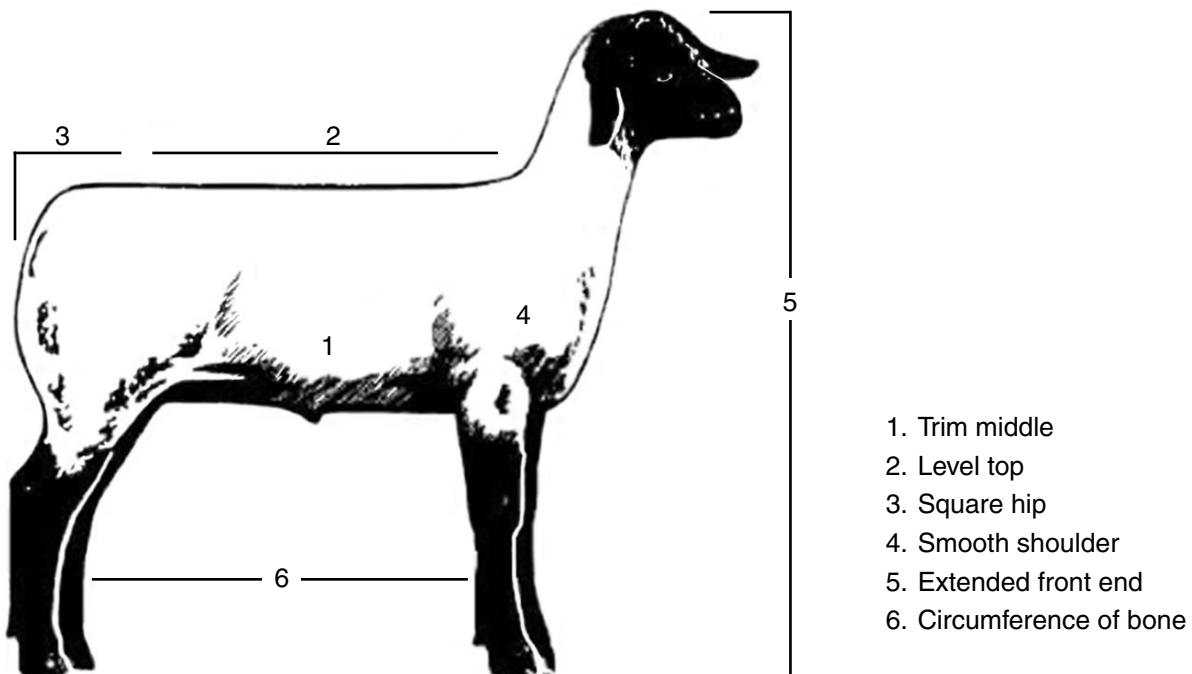

Figure 9. Profile view of a well balanced lamb. (Adapted from Sheep Resource Handbook, 2000)

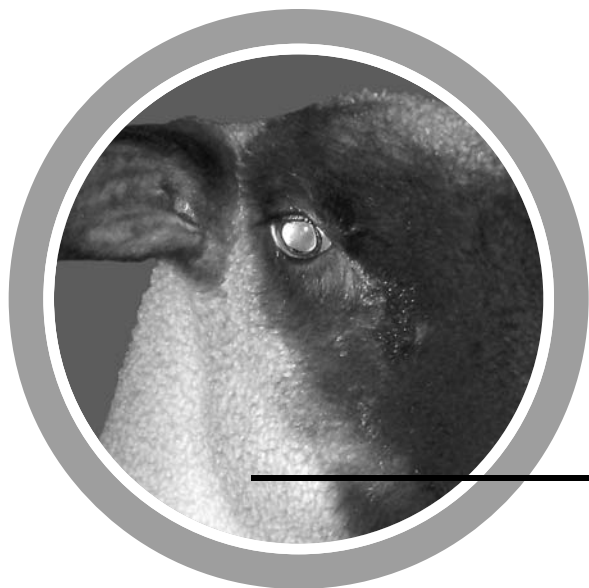

**Table 1. All-American Market Lamb Show Breed Guidelines**

<b>Breed</b>	<b>Three of the following results in disqualification</b>	<b>One of the following results in disqualification</b>
<b>Cheviot</b>	<ol style="list-style-type: none"> <li>1. Solid pink nose</li> <li>2. White hooves</li> <li>3. Long ears and/or extremely long neck</li> <li>4. Excessive brown or black hair (more than 25%)</li> <li>5. Wool cap</li> <li>6. Wool below the knees</li> </ol>	<ol style="list-style-type: none"> <li>1. Horns or solid scurs</li> <li>2. Absence of white hair (frosting) on face and legs of black lambs</li> <li>3. Steep hip and a genetic tendency to be double-muscled</li> </ol>
<b>Columbia</b>	<ol style="list-style-type: none"> <li>1. Scurs</li> <li>2. Solid black nose or pigmented ears</li> <li>3. Excessive black or brown hair (more than 25%)</li> <li>4. Short, thin ears</li> <li>5. Open face or absence of wool cap</li> <li>6. Absence of wool below hock or knee</li> </ol>	<ol style="list-style-type: none"> <li>1. Horns</li> <li>2. Steep hip and a genetic tendency to be double-muscled</li> </ol>
<b>Dorset</b>	<ol style="list-style-type: none"> <li>1. Any dark colored spots in the hair or wool</li> <li>2. Large, drooping ears</li> <li>3. Fine textured, silky hair covering</li> <li>4. Absence of hair covering in typical areas</li> <li>5. All solid black hooves</li> <li>6. Dark colored septum — dividing tissue between the nostrils</li> <li>7. Dark colored lining of the nose or mouth</li> <li>8. All-black, colored or spotted lambs</li> </ol>	
<b>Hampshire</b>	<ol style="list-style-type: none"> <li>1. Broken wool cap</li> <li>2. Very fine or thin hair on face or legs</li> <li>3. Scurs</li> <li>4. Excessive (more than 25%) white hair on jaw or legs</li> </ol>	<ol style="list-style-type: none"> <li>1. Steep hip and genetic tendency to be double muscled</li> <li>2. Horns</li> <li>3. Speckled face so the lamb appears to be a “brockle”</li> <li>4. Excessively dark or blue hide</li> <li>5. Inadequate wool covering on head and legs</li> </ol>
<b>Montadale</b>	<ol style="list-style-type: none"> <li>1. Solid pink nose</li> <li>2. Completely white hooves</li> <li>3. Excessive wool cap</li> <li>4. Heavy wool covering below the hock and knee</li> <li>5. Excessive brown or black hair (more than 25%)</li> </ol>	<ol style="list-style-type: none"> <li>1. Horns</li> <li>2. Excessive dark coloration so lamb appears to be a “brockle”</li> <li>3. Absence of white hair (frosting) on face and legs of black lamb</li> <li>4. Steep hip and a genetic tendency to be double-muscled</li> </ol>
<b>Natural Color</b>	<p>At least 35% black fibers within the fleece, excluding head and legs, is acceptable</p>	

**Table 1. (continued)**

<b>Breed</b>	<b>Three of the following results in disqualification</b>	<b>One of the following results in disqualification</b>
<b>Oxford</b>	<ol style="list-style-type: none"> <li>1. Long, droopy black ears</li> <li>2. Bare face</li> <li>3. Black spots in wool or hair</li> <li>4. Inverted eyelids</li> </ol>	<ol style="list-style-type: none"> <li>1. Speckled face and/or legs</li> <li>2. Horns or solid scurs</li> <li>3. Lack of topknot</li> <li>4. Long, slick, droopy black ears</li> <li>5. Steep hip and genetic tendency to double muscle and white spots on the ear</li> </ol>
<b>Shetland</b>	<ol style="list-style-type: none"> <li>1. Long, heavy tail, broad to point</li> <li>2. Deformities of jaws</li> <li>3. Undersized animal for its age</li> <li>4. Narrow or swayed back</li> <li>5. Close-set and crooked legs</li> </ol>	<ol style="list-style-type: none"> <li>1. Docked tail</li> <li>2. Horns, if present, growing toward the head or neck so as to be life threatening</li> </ol>
<b>Shropshire</b>	<ol style="list-style-type: none"> <li>1. Coarse or long, droopy ears</li> <li>2. Coarse or roman nose</li> <li>3. Excessive white on face, ears or legs</li> <li>4. Legs completely bare of wool below the knee and hock</li> <li>5. Black armpits or black spots in skin or wool</li> </ol>	<ol style="list-style-type: none"> <li>1. Horns</li> <li>2. Lack of wool cap</li> <li>3. Steep hip and a genetic tendency to be double-muscled</li> </ol>
<b>Southdown</b>	<ol style="list-style-type: none"> <li>1. Solid white hair color on muzzle</li> <li>2. Pink nose</li> <li>3. Excessive white on face, ears or legs</li> <li>4. Completely slick ears</li> <li>5. Pink or striped hooves</li> <li>6. Black spots in the fleece</li> <li>7. Open pool on the head</li> </ol>	<ol style="list-style-type: none"> <li>1. Speckled face or legs</li> <li>2. Horns or solid scurs</li> <li>3. Solid black lambs</li> <li>4. Steep hip and a genetic tendency to be double muscled</li> </ol>
<b>Suffolk</b>	<ol style="list-style-type: none"> <li>1. White in face and legs 20%</li> <li>2. Wool on head</li> <li>3. Coarse hair on head and legs</li> <li>4. Short, thick ears</li> <li>5. Wool on legs</li> <li>6. Brown, not black, head</li> <li>7. Hooves not black</li> </ol>	<ol style="list-style-type: none"> <li>1. Excessively blue or dark hide</li> <li>2. Speckled face or legs</li> <li>3. Horn</li> </ol>



# Health

A basic understanding of sheep health can be very valuable throughout the months of your project. Having the ability to recognize health problems quickly and begin a treatment protocol is important to prevent unexpected decreases in lamb performance. Below are a list of common market lamb diseases, along with symptoms, prevention protocols and available treatments.



Disease	Organism/ Cause	Time of Occurrence	Clinical Signs	Possible Treatment	Prevention/ Vaccination	Remarks
<b>Enterotoxemia</b>	Clostridial Perfringens C & D	Anytime	Convulsions, sudden death.	Administration of the C & D antitoxin according to the label instructions, plus an injection of penicillin.	Vaccination of ewes and lambs.	Also referred to as "overeating" disease
<b>Hoof Rot</b>	Anaerobic bacteria; <i>Dichelobacter nodosu</i>	Wet, damp conditions	Severe lameness accompanied with foul-smelling odor. Decreased rate of gain.	Isolate infected animals, trim hooves, apply antibiotic agents directly to hoof. Injection of tetracycline or penicillin also may be needed.	Vaccine is available but yields variable results. Trim hooves, maintain dry housing conditions.	Zinc or copper sulfate foot baths are helpful.
<b>Pneumonia</b>	Multiple: bacteria, viruses, stress, dehydration, improper ventilation	Anytime	Fever, decreased rate of gain, cough, abnormal breathing, nasal discharge, lethargy.	Various antibiotic treatments available dependent on known cause.	Proper management techniques.	Also referred to as "shipping fever."
<b>Rectal Prolapse</b>	Short tail docking, coughing, diet, age, scours, heredity, sex and/or pregnancy	Anytime	Rectal tissue protrudes outside the anus. Bright red tissue will protrude during straining or coughing.	Discuss options with your veterinarian. Proper treatment will depend on stage of prolapse.	Proper management techniques. Culling. Proper docking length. Reduce incidence of scours and cough.	Suturing is only a temporary solution until slaughter.



**Common  
Market  
Lamb  
Diseases**

<b>Disease</b>	<b>Organism/ Cause</b>	<b>Time of Occurrence</b>	<b>Clinical Signs</b>	<b>Possible Treatment</b>	<b>Prevention/ Vaccination</b>	<b>Remarks</b>
<b>Ringworm</b>	Trichophyton fungi	1-4 weeks after exposure to the fungus	Circular, thick, flakey lesions.	Topical antifungal medications. Discuss options with veterinarian. May take 8-16 weeks for recovery.	Frequent washing and close shearing promotes susceptibility, stress weakens immune system. Disinfect equipment with antifungal agents.	Use caution, transmissible to humans. Many shows do not allow exhibition of lambs with this contagious disease.
<b>Scours</b>	Bacteria, viruses, protozoa, stress, poor ventilation, abrupt feed changes	Anytime	Abnormal frequency, fluidity or volume of fecal excretion. Dehydration. Death.	Antibiotics and electrolytes to prevent excessive dehydration. Discuss treatment options with veterinarian.	Sanitation, dry, clean bedding, reduce stress levels, limit drastic nutritional changes.	
<b>Soremouth</b>	Pox virus	Anytime	Scabs or blisters forming around lips, flanks, vulva, teats.	7% iodine solution applied to scabs.	Live vaccine is available.	Use caution, transmissible to humans.
<b>Urinary Calculi</b>	Increased levels of calcium, magnesium, phosphorus and potassium in the diet	Anytime	Painful and swollen penis, infrequent or irregular urination.	Oral dose of ammonium chloride. Discuss options with veterinarian.	Maintain 2:1 calcium-phosphorus ratio in diet. Add ammonium chloride to ration to acidify urine, preventing mineral buildup.	Commonly found in wether lambs.
<b>White Muscle Disease</b>	Diets deficient in selenium and/or vitamin E	Usually after lambing	Stiffness, hunched back, mild paralysis and/or starvation.	Injection of selenium and vitamin E: Bo-Se or Mu-Se.	Supplement vitamin E and selenium in diet.	
<b>External Parasites</b>	Wool maggots, sheep bot, sheep keds and lice	Anytime	Unthriftiness, anemic, decreased weight gain.	Apply insecticide.	Shearing, clip and disinfect soiled or matted areas and apply insecticides.	
<b>Internal Parasites</b>	Roundworms, tapeworms, flukes and lungworms	Anytime	Unthriftiness, anemic, decreased weight gain.	Administer dewormer.	Obtain a proper dewormer protocol from your veterinarian.	

**Typical Values for a Healthy Club Lamb**  
 Body Temperature .....102.8 degrees Fahrenheit  
 Pulse/Heart Rate .....75 beats/minute  
 Breathing Rate.....20 breaths/minute



# Nutrition and Exercise

---

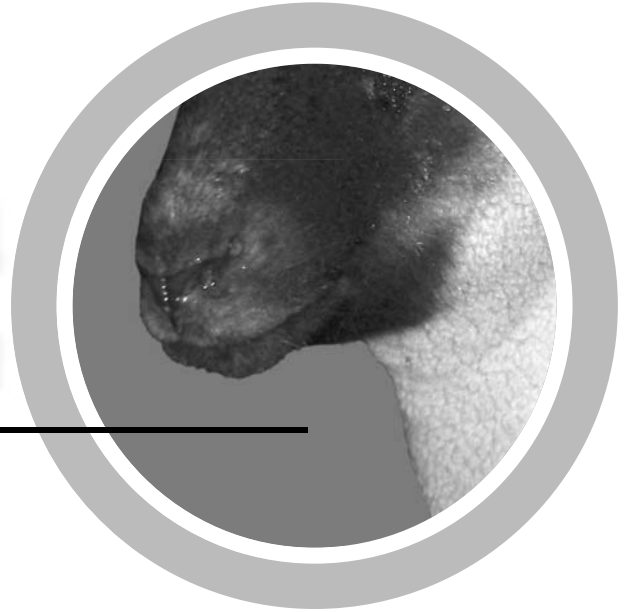

**T**here is no show lamb ratio available that will guarantee a champion. A competitive lamb is a combination of selection, management, nutrition, exercise and showmanship. To develop a successful feeding program, you must closely observe the changes in the lamb throughout the feeding program. The exhibitor must have the ability to use all of the available information to decide when and how feed changes should be made. A good relationship with your local nutritionist or the breeder of your show lamb can be beneficial to help in guiding you through your feeding protocol.

Overall, basic nutrition plays a major role in the productivity, health and well-being of your project. The six major categories of nutrients required by sheep are: 1) water, 2) carbohydrates, 3) protein, 4) minerals, 5) vitamins and 6) fats.

## **Water**

One of the most commonly overlooked nutrients when formulating rations for all livestock species is water. Water plays an important role in vital functions, such as digestion, nutrient transport, waste excretion and temperature regulation, which all allow for optimum growth and performance of the show lamb. On average, a typical lamb will consume 1 to 2.5 gallons of water a day, depending on temperature, feed additives and overall health of the lamb.

## **Carbohydrates**

The primary energy source found in sheep rations are carbohydrates. Microbes inside the rumen break down carbohydrates, forming volatile fatty acids. Fatty acids are absorbed via the small intestine and utilized as energy for the lamb. Carbohydrates tend to be the most common limiting factor in lamb diets. Inadequate energy intake reduces growth potential and causes weight loss. The relative energy value of a feed can be represented as TDN (total digestible nutrients). In the ration, corn is considered a major carbohydrate source.

## **Protein**

Aside from water, protein makes up the highest nutrient composition in show lamb diets. Proteins are responsible for protecting the body (wool and hair), digesting food (enzymes) and stimulating growth (hormones). In young growing lambs, protein requirements generally are higher and decline as the growth rate declines. A typical show lamb ration will be 16 percent to 18 percent protein. Soybean meal serves as the main protein source in most rations.

## Vitamins

Vitamins are organic substances required by all livestock species. Vitamins fall into two subgroups: fat soluble and water soluble. The water-soluble vitamins are C and the vitamin B-complex. Fat-soluble vitamins are A, D, E and K. Most lambs suffer from a minor deficiency in vitamin A. Discuss the ration vitamin supplement with your nutritionist to prevent any deficiency problems in your ration.

## Minerals

Minerals are inorganic compounds found in the diet and are unable to be broken down by chemical reactions. Minerals are classified based on their level found in the diet: macro- and micro-minerals. Macro-minerals (exceeding 100 parts per million, or ppm) include minerals such as calcium, phosphorus, chlorine, magnesium, potassium, sodium and sulfur. Micro-minerals (below 100 ppm) include chromium, cobalt, copper, fluorine, iron, selenium, zinc and iodine. When raising a market lamb, never feed mineral supplements labeled for other species. Mineral supplements generated for other species will contain higher amounts of copper. Sheep have a very low tolerance for copper (less than or equal to 5 ppm), and if ingested at higher levels, toxicity will occur.

**Table 2. Estimated dry matter (DM), energy (TDN) and crude protein (CP) requirements of rapidly growing market lambs (average daily gain of 0.9 lb).**

Lamb weight (lbs.)	DM intake (lbs.)	TDN intake		CP intake	
		(lbs.)	% of diet	(lbs.)	% of diet
60 to 90	2.6	1.7	66	0.5	18
90 to 120	3.2	2.0	62	0.5	16
120 to 150	4.7	2.6	55	0.7	15

**Table 3. Example rations balanced to meet the nutrient requirements of the market lamb.**

Ingredients for <b>Ration #1</b>	Amount (lbs.) needed for mixing a 100-lb. batch	Amount (lbs.) needed for mixing 2,000-lb. batch
Rolled Corn	50	1,000
Rolled Oats	9	180
Rolled Barley	9	180
Soybean Meal	20	400
Molasses	10	200
Sheep Mineral	1	20
Limestone	1	20

Ingredients for <b>Ration #2</b>	Amount (lbs.) needed for mixing a 100-lb. batch	Amount (lbs.) needed for mixing 2,000-lb. batch
Rolled Corn	50	1,000
Sheep Balancer B136 Medicated*	20	400
Rolled Oats	10	200
Soybean Meal	9.2	184
Molasses	10	200
White Salt	0.4	8
Ammonium Chloride	0.4	8

\*Commercially available pellet (37% protein) containing 27.2 grams per ton lasalocid (Bovatec).

## **Fat**

Fats are used to provide energy and fatty acids for the lamb. They serve as a concentrated form of stored energy.

Listed below are a few dealers from throughout the nation that supply complete show lamb mixes and/or top dresses. Purchases can be made through the internet and shipped to your home. Show lamb mixes also can be purchased from your local feed cooperative. Contact your Extension agent for local listings of feed companies in your area.

### **Champions Choice**

[www.championschoicesupplements.com](http://www.championschoicesupplements.com)

### **High Noon Feeds LLC**

[www.highnoonfeeds.com](http://www.highnoonfeeds.com)

### **Honor Showlamb Feeds**

[www.showchow.com](http://www.showchow.com)

### **Kent First Rate Lamb Feeds**

[www.kentshowfeeds.com](http://www.kentshowfeeds.com)

### **MoorMan's ShowTec**

[www.admani.com](http://www.admani.com)

### **SFI Show Feeds**

[www.showfeedsinc.com](http://www.showfeedsinc.com)

### **Starmaster Show Feeds**

[www.starmastershowfeeds.com](http://www.starmastershowfeeds.com)

### **Suther's Feeds**

[www.sutherfeeds.com](http://www.sutherfeeds.com)

## **Exercise**

Exercising your lamb throughout the project months is necessary to maintain a lamb that handles fresh and firm, and is properly finished. Exercise and proper nutrition coincide to help formulate the ideal lamb for show day. You have many different ways to exercise show lambs, depending on space, time and equipment availability. The main goal in the exercise program should be to provide a significant stimulus to encourage the development of muscle and, in some cases, reduce the rate of fat deposition.



# Fitting

---

**F**itting lambs for a show requires washing, shearing and conditioning. Prior to shearing, lambs should be washed using a livestock or liquid dish soap, being careful to rinse out all of the soap. Try to avoid soap contact with ears, eyes and lips, where irritation may occur. After washing, use a bath towel or blower to remove most of the moisture from the wool and head. Shearing can be done while the wool still is damp, not wet. Clippers fitted with a 20-tooth comb and four-point cutter or a 23-tooth comb and nine-point cutter can be used to remove a majority of the wool. Most market lamb exhibitors will follow with a set of fine or surgical hair blades to ensure a smooth, tight cut without the appearance of clipper lines. While shearing, the clippers should run parallel to the length of the body rather than vertically.

Shearing parallel to the body makes lambs appear balanced and longer bodied. Wool below the knees and hocks should not be shorn. This portion of the legs can be carded and blended with hand shears. Use a small clipper to clip the head and ears, being careful to avoid contact with the eyes. After shearing, the lamb should be conditioned, blanketed and put into a clean, dry pen. Conditioning the lamb helps restore some of the moisture lost in the shearing process. Commercial conditioners, such as Freshen Up or Sullivan Silk, can be used; however, homemade mixes work well also. Mix 1 part hair conditioner to 3 parts water in a spray bottle and apply as needed. Immediately following the conditioning process, a lamb tube and/or canvas blanket should be placed on the lamb to maintain cleanliness. Try to wash and shear as close to show day as possible to avoid excessive wool growth.

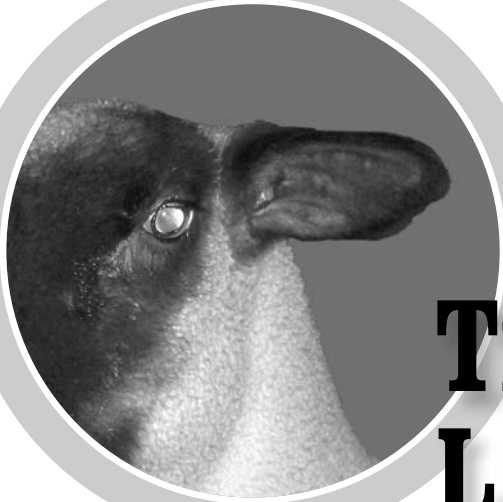

# Training Your Lamb to Show

**P**ractice showing should take place at home as soon as the lamb arrives. Breaking the lamb to lead and brace will not happen immediately; it will take many weeks to train your show lamb to respond adequately to your cues.

Teaching your lamb to lead should be one of the first priorities when you begin to work with your lamb. Breaking the lamb to lead by halter and by hand may be difficult; however, with time and patience, it will become much easier. When halter breaking, lambs should be caught, haltered and tied to a fence with the lamb's head in an upright, yet comfortable, position. While the lamb is tied, the exhibitor should work with the lamb by setting the feet and legs. Never leave tied lambs unattended; strangulation and/or death may occur.

After the lamb has been accustomed to the halter breaking process, leading the lamb is the next step. When leading the lamb, a gentle pull should be applied to the rope halter. If the lamb resists, ask an adult or older sibling to apply light pressure to the tail to initiate forward movement.

After the lamb has been halter broken successfully, teaching the lamb to lead without the halter is the final step in the leading process. The exhibitor should walk on the left side of the lamb, moving slowly with the left hand under the lamb's lower jaw and using the right hand to apply a gentle but firm pressure at the back of the

head. If the lamb resists, place the right hand on the lamb's dock to encourage movement forward.

Once the lamb has been trained to lead, teaching it to set up and brace is the final step. Set the lamb squarely on all four feet, maintaining control of the lamb with the left hand under the chin and using the right hand to reach over the lamb to set the feet. Always set the rear legs first and then move to the front legs. When setting the lamb's legs, pick up the leg and set it down in one smooth motion. The lamb will fight less if you pick up the leg above the knee or hock. When the



**Figure 10. Profile bracing view. Notice the exhibitor's hand and feet placement. The lamb is set square; the neck is extended upward, with the nose level; and the ears are pointed up and forward.**

lamb is set, stand with the head and neck high with the ears pointing up and outward.

Bracing a lamb requires careful cooperation between the exhibitor and the lamb. Bracing refers to the forward push or drive of the lamb against the inner portion of the showman's thigh. This helps make the lamb feel firm and trim when handled by the judge. Training the lamb to brace at a constant, steady pressure for long periods of time (approximately five minutes) is important. Teaching the lamb to brace requires time and practice at home. Try to avoid lifting the lamb off the ground while bracing; this will weaken the top line and look unnatural. The upward lift also may teach the lamb to jump into you while attempting to obtain a brace. A lamb can be trained to brace by simply walking it backward while maintaining constant pressure between the lamb's chest and the exhibitor's inner thigh.

When the lamb is able to respond to the personal cues from the exhibitor, an older adult should "handle" the lamb while bracing to accustom the lamb to the handling process that will occur in the show ring. The judge will begin by handling the lamb's rack and gradually work his hand down to the lamb's leg. This handled area of the lamb should be full and firm, with no evidence of the spine.

When evaluating the muscle over the loin, the judge will look for three areas: width, depth and length. Width can be obtained by placing the thumb on one edge and reaching across to the other edge. The wider the loin, the more retail product available after slaughter. Depth of the loin muscle is found by gripping the loin edge gently between the thumb and index finger. Lastly, length is determined by measuring the distance



**Figure 11. Rear bracing view. Notice the exhibitor's hand placement. The lamb's nose, neck and spine should be in a straight line. Rear legs should be set wider than the front legs.**



**Figure 12. Front view. Notice the exhibitor's hand and body placement. The lamb's nose should point forward, with ears placed up and forward.**

between the last rib and hip bone. Moving from the loin area, the judge will evaluate the size and tone of muscle in the leg. The judge will place his index fingers together on the inner side of the

lamb and reach around the front side to see how close they come together. Secondly, he will place his hand on the backside of the leg to feel the firmness of the leg muscle.



**Figure 13. Judge handling dimension of the rack.**



**Figure 14. Measuring length of loin.**

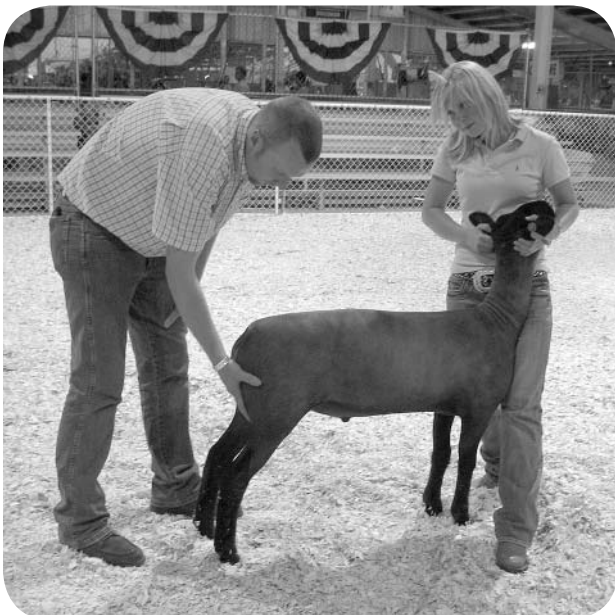

**Figure 15. Judge handling lower leg.**

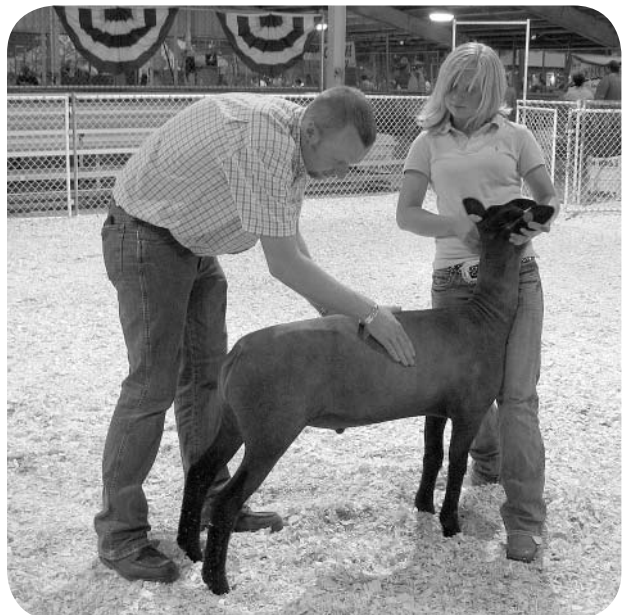

**Figure 16. Checking degree of finish over the ribs.**



# Showmanship

---

**S**howmanship is judged on the exhibitor's ability to control and present the lamb to the best of its ability. Realize that engaging in showmanship is important because it not only teaches the exhibitor how to present the lamb, but more importantly, it promotes responsibility, determination, goal setting and sportsmanship attributes. Showmanship begins at home following many hours of practice with the lamb. A good showmanship lamb should be quiet and calm, and respond quickly to your cues to turn, stop, move forward and brace.

## The Exhibitor

The exhibitor should dress neatly and be presented in a professional manner to portray a positive image to the judge. Wear a clean, tucked-in, button-down or polo shirt, belt and nice jeans. Leather boots are also a necessity for safety and appearance. Never wear hats, flip-flops, tennis shoes, T-shirts or shorts when exhibiting market lambs.

The exhibitor is responsible for being familiar with the show schedule and watching classes before their own. By watching other classes, exhibitors can pick up on what the judge is expecting from the showmanship classes. Be familiar with the ring setup and how to maneuver around the ring effectively, and be prepared if questions are asked.

## The Lamb

Like the exhibitor, the lamb should be presented in a professional manner. The lamb should be fitted to meet the requirements of the show. Before entering the ring, wipe the nose with a damp cloth and check for saw dust, straw and

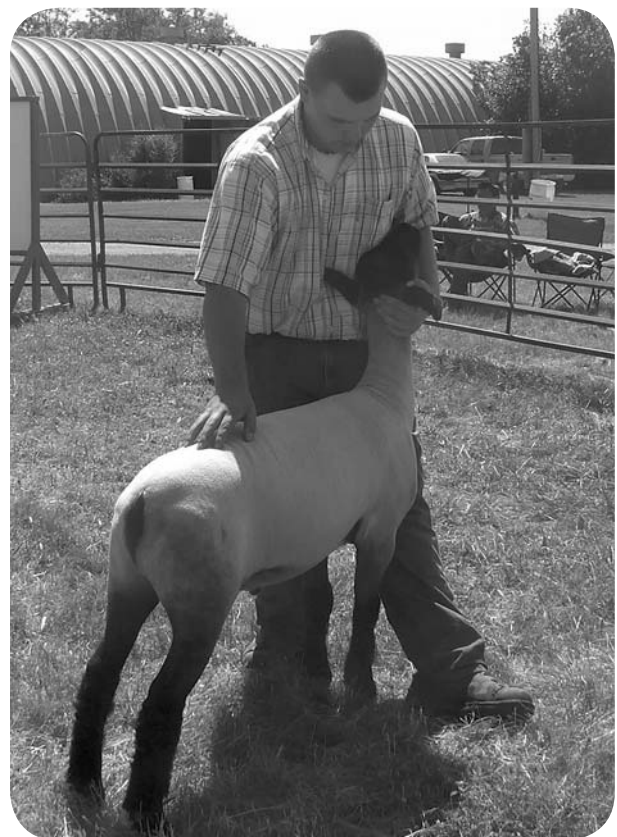

**Figure 17. Example of a well-dressed showman.**



other bedding particles on the legs and underline. The exhibitor should enter the ring on time and assist other exhibitors if needed. Be aware of the judge's position at all times and try to keep the lamb between you and the judge. Pay attention to what is taking place in the ring and always follow the judge's or ringman's instructions correctly. Avoid verbal and eye contact with adults or mentors standing along the sideline of the show ring.

Be courteous, pleasant (smile softly) and stay alert. Do not maintain steady eye contact with the judge. A good showman will glance between the judge and the lamb, making periodic eye contact with the judge, yet still maintaining a primary focus on the lamb. Work gently and calmly with the lamb in the ring, trying to avoid any sudden movements. Try to maintain a well-posed lamb; any unnecessary fussing or maneuvering with the lamb will distract the judge. Any inappropriate physical contact with the lamb (slapping, hitting, etc.) will be penalized severely in class standing.

When moving about the ring, always walk on the left hand side in a clockwise direction. Do not crowd other exhibitors and maintain a straight line. Never step over the back or behind your lamb and avoid resting your arm or hands on the top of the lamb's back. When exhibiting the lamb's profile (side view), you may brace the lamb or kneel beside it. If kneeling beside the lamb, avoid

kneeling in the sawdust or dirt of the show ring. Never stop showing your lamb until you leave the ring or some judges may change their final placing. Always shake hands and congratulate the class winner in your division. If selected to win the division, always shake hands with the judge following the class.

Lastly, remember that showmanship is a learning process. Never give up based on class standing and try to learn from your mistakes. Watch other exhibitors, ask questions and try to improve your skills for future shows. Good luck!

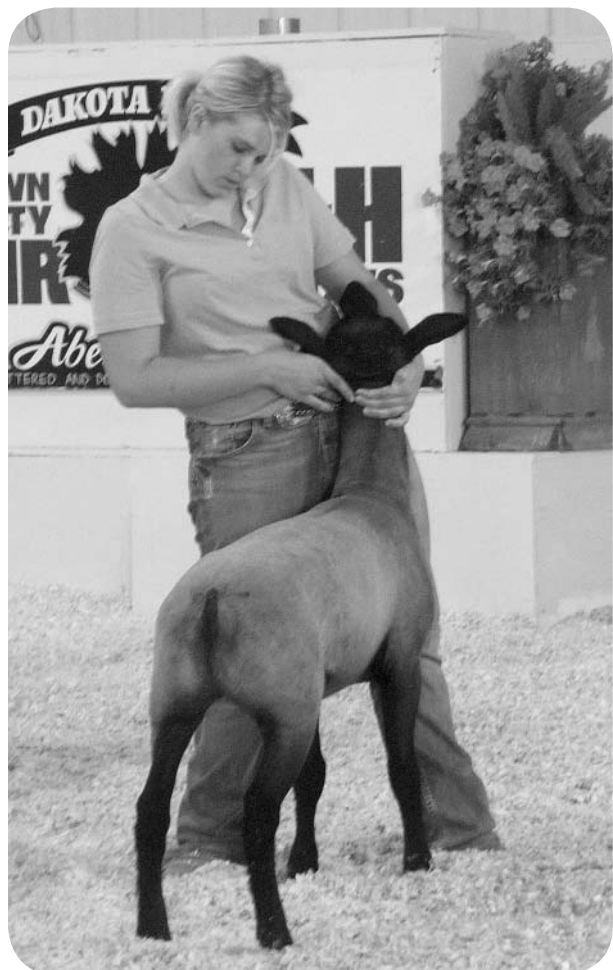
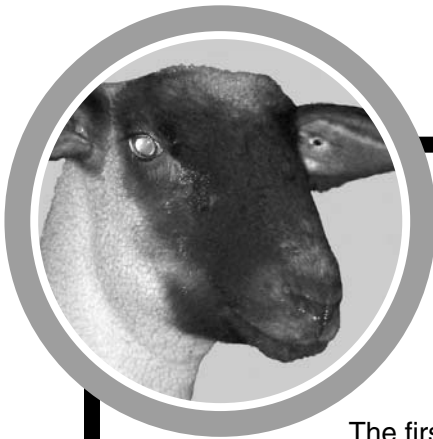

**Figure 18. Example of a nicely fitted lamb for showmanship.**

## Common Showmanship Questions

Listed below are some questions judges commonly ask during showmanship classes. These questions range in difficulty; as a showman becomes older, the questions will become more difficult.

1. What breed is your sheep?
2. What is the exercise program for your lambs?
3. What does your lamb weigh?
4. When was your lamb born?
5. What do you feed your lamb?
6. How much do you feed your lamb?
7. What is the percent of crude protein in your feed ration?
8. What would you like to change about your lamb?
9. Where is the (loin, hind saddle, poll, etc.) located on your lamb?
10. What is the average loin eye size for market lambs?
11. What is the average amount of backfat for market lambs?
12. Name two sheep byproducts.
13. What is the pelt value of your lamb?
14. How many parts are there to the sheep stomach? Can you name them?
15. Name examples of meat breeds.
16. Name examples of wool breeds.
17. What is the gestation length of a ewe?
18. What is the average dressing percent of market lambs?
19. How many pounds of feed must be fed for 1 pound of gain?
20. What is the normal body temperature of a sheep?
21. How many teeth does a lamb have? A mature sheep?
22. Which lamb do you like in the class? Why?
23. Which showman do you like in the class? Why?
24. What is the health program for your lamb?



## Establishing Project Goals

The first step involved in the youth market lamb project, as in any project, is to establish goals. You will need to decide the level at which you will want to compete. If this is your first year, you may choose to exhibit your lamb(s) only at the county or community fair. On the other hand, you may have the desire to compete among more individuals from throughout the state by attending one or several of the designated North Dakota Junior Point Shows, or even the North Dakota State Fair. You also could participate in numerous regional and national shows..

Writing down answers to the following questions may help you establish the goals of your project. In addition, reading through the current guide before providing answers the following questions may be useful. The knowledge gained from this guide also will help you establish your project goals.

Is this your first year being involved in the market lamb project? If not, for how many years have you been actively involved?

Why are you interested in the youth market lamb project and what are some of the things you hope to learn?

How many lambs can you take care of in your current facilities?

How much money are you able to spend on your lamb(s)?

Which market lamb shows would you like to attend throughout the year?



A goal of the youth market lamb project is to provide opportunities for children and youth to build character. North Dakota 4-H supports the **CHARACTER COUNTS!SM\* Six Pillars of Character: Trustworthiness, Respect, Responsibility, Fairness, Caring, and Citizenship**. In order to ensure that the youth market lamb project provides a positive environment for all individuals to learn and grow, participants should agree to abide by these expectations of behavior.

**I will be trustworthy.** I will be worthy of trust, honor and confidence. I will be a model of integrity by doing the right thing even when the cost is high. I will be honest in all my activities. I will keep my commitments by attending all sessions of a planned event.

**I will be respectful.** I will show respect, courtesy, and consideration to everyone, including myself, other program participants, and those in authority. I will act and speak respectfully. I will treat program areas, lodging areas, personal property and transportation vehicles with respect. I will follow all published dress code guidelines for an event and/or activity.

**I will be responsible.** I will be responsible, accountable, and self-disciplined in the pursuit of excellence. I will live up to high expectations so I can be proud of my work and conduct. I will be on time to all program events. I will be accountable by accepting responsibility for my choices and actions.

**I will be fair.** I will be just, fair, and open. I will participate fairly by following the rules, not taking advantage of others and not asking for special exceptions. I will not cheat or misrepresent project work.

**I will be caring.** I will be caring in my relationships with others. I will be kind and show compassion for others. I will treat others the way I want to be treated. I will show appreciation for the efforts of others. I will help others to have a good experience by striving to include all participants.

**I will be a good citizen.** I will be a contributing and law-abiding citizen. I will be respectful to the environment and contribute to the greater good.

\* CHARACTER COUNTS! is a service mark of the CHARACTER COUNTS! Coalition, a project of the Josephson Institute of Ethics.

## Citation:

Sheep Resource Handbook for Market and Breeding Projects. 2000.  
Curriculum Materials Service. Ohio State University Extension Service.

The NDSU Extension Service does not endorse commercial products or companies even though reference may be made to tradenames, trademarks or service names.

This publication may be copied for noncommercial, educational purposes in its entirety with no changes. Requests to use any portion of the document (including text, graphics or photos) should be sent to [NDSU.permission@ndsu.edu](mailto:NDSU.permission@ndsu.edu). Include exactly what is requested for use and how it will be used.

**For more information on this and other topics, see: [www.ag.ndsu.edu](http://www.ag.ndsu.edu)**

County commissions, North Dakota State University and U.S. Department of Agriculture cooperating. North Dakota State University does not discriminate on the basis of race, color, national origin, religion, sex, disability, age, Vietnam Era Veterans status, sexual orientation, marital status, or public assistance status. Direct inquiries to the Chief Diversity Officer, 205 Old Main, (701) 231-7708. This publication will be made available in alternative formats for people with disabilities upon request, (701) 231-7881.

750-1-09